

- Notes:
1. Infeed Height = 47"
  2. Overall Height = 92"
  3. Indexing Conveyor Belt Height = 24"
  4. Box Size = 10 5/8" L x 7 3/8" W x 8 1/2" H open
  5. Pan Surface = Flat SS
  6. Frame Material = 304SS
  7. All equipment to have casters

Power Requirements:  
 Scale - (2) 20A 120VAC @ 60Hz separate circuits  
 Index Conveyor - (1) 5A 220VAC 3 Phase  
 Incline Conveyor - (1) 5A 220VAC 3 Phase

Air Requirements:  
 10 CFM @ 100PSI

Approval:  
 Sign: \_\_\_\_\_  
 Print: \_\_\_\_\_  
 Date: \_\_\_\_\_

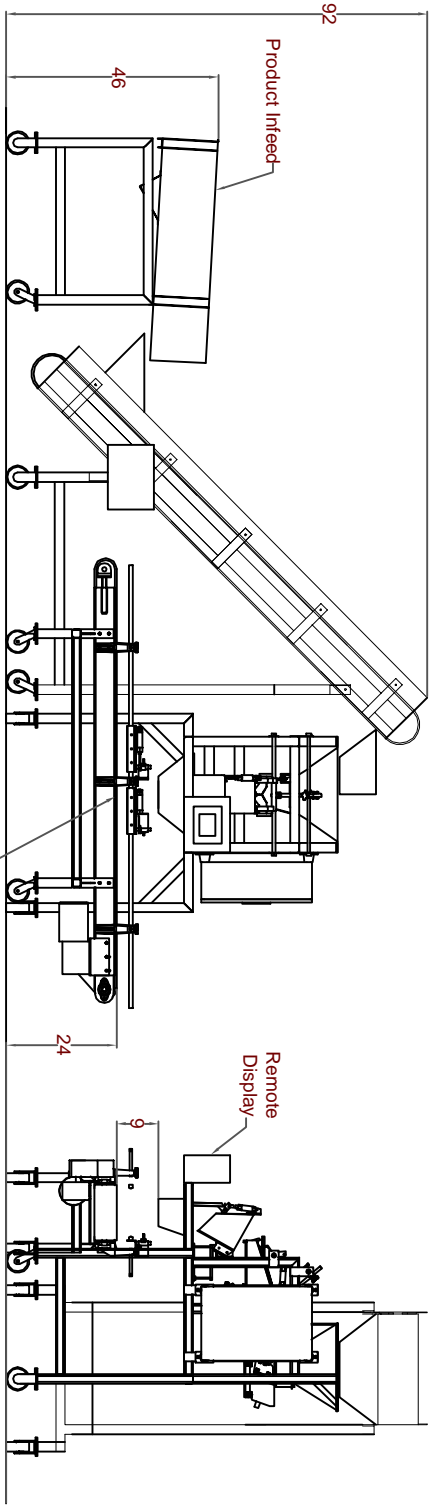

Direction Of Flow  
 →

Setting Feature  
 To Be Directly  
 Under Box Fill

DRAWN	W Marchand	2/28/2006	Ohlson Packaging	
CHECKED			TITLE	
QA			1M2 - Index - Incline - Hopper	
MFG			SIZE	DWG NO
APPROVED			A	Parmalat Cheese
			SHEET	1 OF 1
			REV	A